

Pressure Control Valves

Pressure Reducing Valves DM 604

Standard Cast Valve



Technical Data

Connection DN	15 - 150
Nominal Pressure PN	16 - 40
Inlet Pressure	up to 40 bar
Outlet Pressure	0.02 - 10 bar
K _{vs} -Value	4 - 160 m ³ /h
Temperature	250 °C
Medium	steam

Description

Self-acting pressure reducers are simple control valves offering accurate control while being easy to install and maintain. They control the pressure downstream of the valve without requiring pneumatic or electrical control elements.

The DM 604 pressure reducing valve is a diaphragm-controlled spring-loaded proportional control valve for high temperatures and large volumes. The valve cone is fitted with a metallic seal (up to 250 °C).

The outlet pressure to be controlled is balanced across the control unit by the force of the valve spring (set pressure). As the outlet pressure rises above the pressure set using the adjusting screw, the valve cone moves towards the seat and the volume of medium is reduced. As the outlet pressure drops, the valve control orifice increases; when the pipeline is depressurised, the valve is open. Rotating the adjusting screw clockwise increases the outlet pressure.

The valves requires a sense line (to be installed on-site).

These valves are no shut-off elements ensuring a tight closing of the valve. In accordance with DIN EN 60534-4 and/or ANSI FCI 70-2 they may feature a leakage rate in closed position in compliance with the leakage classes III (metal sealing cone - 0.1 % K_{vs} value).

Standard

- » balanced cone for controlling the outlet pressure independently from the initial pressure
- » open spring
- » pilot line connection

Options

- » spring cap
- » pneumatic actuation
- » for toxic or hazardous media: sealed spring cap complete with leakage line connection (incl. sealed adjusting screw). Must be installed with a leakage line capable of draining leaking medium safely and without pressure
- » various diaphragm and seal materials suitable for your medium
- » special versions on request

Operating instructions, know how and safety instructions must be observed. All the pressure has always been indicated as overpressure. We reserve the right to alter technical specifications without notice.



ill. similar

K _{vs} -Values [m ³ /h]										
DN	15	20	25	40	50	65	80	100	125	150
m ³ /h	4	5	6	20	32	50	80	100	140	160

Setting Ranges [bar], Nominal Pressure PN						
DN 15-50	0.02 - 0.25	0.1 - 0.6	0.2 - 1.2	0.8 - 2.5	2 - 5	4.5 - 10
DN 65-100	0.02 - 0.25	0.1 - 0.6	0.2 - 1.2	0.8 - 2.5	2 - 5	4 - 8
DN 125+150	0.05 - 0.25	0.1 - 0.6	0.2 - 1.2	0.8 - 2.5	2 - 3.5	2 - 5
PN	40/1	40/1	40/2.5	40/6	40/10	40/16

Pressure Control Valves

Pressure Reducing Valves DM 604

Standard Cast Valve



Materials	
Temperature	250 °C
Body	cast steel optional CrNiMo-steel
Diaphragm Housing	steel welded optional CrNiMo-steel
Spring Cap	steel welded optional CrNiMo-steel
Spring	spring steel C optional CrNi-steel
Diaphragm	EPDM
O-Ring (balance)	FXM

Dimensions [mm]											
size	pressure range bar	nominal diameter DN									
		15	20	25	40	50	65	80	100	125	150
A	0.02-5/8/10	130	150	160	200	230	290	310	350	400	480
B		55	55	55	75	75	105	105	105	220	220
C	4.5 - 8/10	530	530	530	560	560	640	640	640	940	940
C ₁	2 - 3.5/5	660	660	660	720	720	800	800	800	1100	1100
D	0.8 - 2.5	175	175	175	220	220	220	220	220	220	220
C	0.2 - 1.2	540	540	540	560	560	640	640	640	840	840
C ₁		670	670	670	720	720	800	800	800	1000	1000
D		220	220	220	270	270	270	270	270	270	270
C	0.1 - 0.6	540	540	540	560	560	640	640	640	840	840
C ₁		670	670	670	720	720	800	800	800	1000	1000
D		270	270	270	360	360	360	360	360	360	360
C	0.02/0.05 - 0.25	510	540	540	560	560	640	640	640	840	840
C ₁		670	670	670	720	720	800	800	800	1000	1000
D		360	360	360	360	360	360	360	360	500	500

Weights [kg]											
nom. pressure	pressure range bar	nominal diameter DN									
		15	20	25	40	50	65	80	100	125	150
PN 16	0.8 - 5/8/10	17	17	18	30	33	55	58	62	100	120
	0.2 - 1.2	19	19	20	32	35	57	60	64	102	122
	0.1 - 0.6	23	23	24	36	39	61	64	68	106	126
	0.02/0.05-0.25	23	23	24	34	37	59	62	66	112	132
PN 25/40	0.8 - 5/8/10	18	18	19	33	35	58	62	65	108	133
	0.2 - 1.2	20	20	21	35	37	60	64	67	110	135
	0.1 - 0.6	24	24	25	39	41	64	68	71	114	139
	0.02/0.05-0.25	24	24	25	37	39	62	66	69	120	145

Customs Tariff Number
84811019

Special designs on request.
The pressure has always been indicated as overpressure.
Mankenberg reserves the right to alter or improve the designs or specifications of the products described herein without notice.

Dimensional Drawing

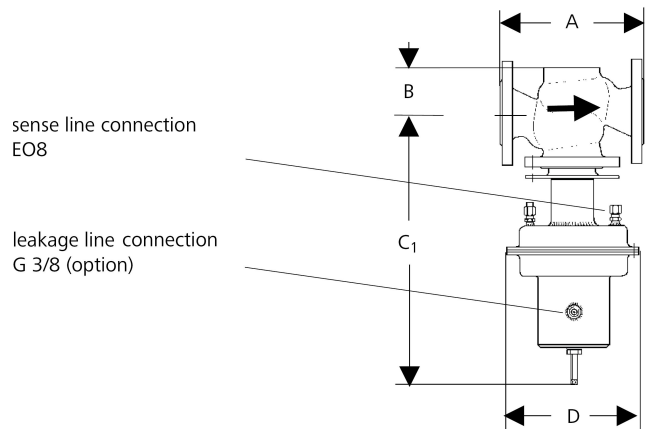
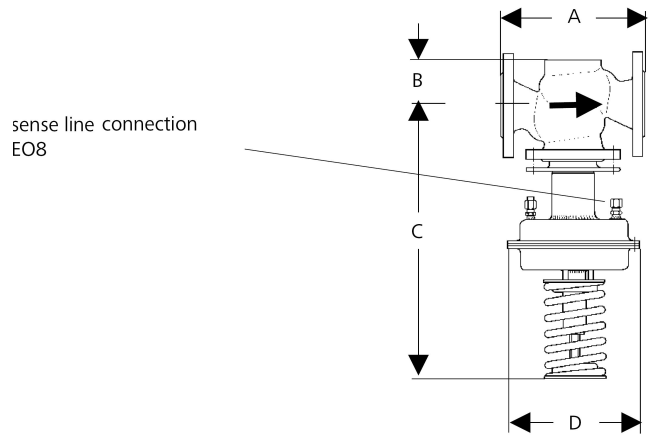

Recommended Installation

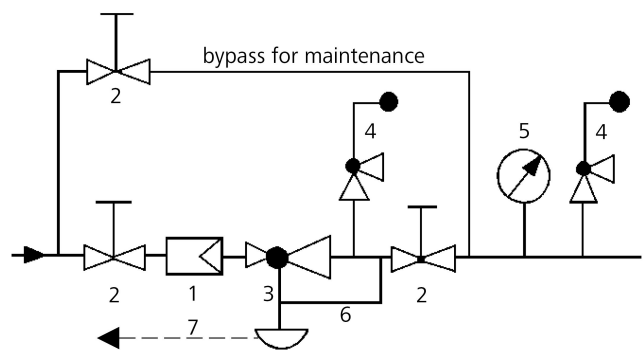

- 1 Strainer
- 2 Shut-off Valves
- 3 Pressure Reducer
- 4 Safety Valves
- 5 Pressure Gauge
- 6 Sense Line EO8
- 7 Leakage Line G 3/8 (option)

sense line connection 10 - 20 x DN behind the valve
use MANKENBERG-Products